

Emergency Chlorine Scrubber System – EVS Series

The EVS-150 emergency chlorine scrubber is a multistage wet scrubber system designed to treat chlorine vapors from a bank of 150lb (70kg) chlorine cylinders, at leak rates of 28 lbs/min or more, exceeding the requirement of the Uniform Fire Code. The EVS-150 system is designed to maintain negative pressure in the chlorination and chlorine storage rooms, while limiting the atmospheric release of chlorine to less than 1 ppm.

The factory-assembled EVS-150 system is very compact, with low profile suitable for either indoor or outdoor installation. It is designed by **Roop Jain**, a renowned leader and innovator in chlorine scrubber technology for the last 25 years.

Guaranteed Performance

- The EVS-150 scrubber is capable of reducing the inlet chlorine gas concentration to less than 1 ppm at the outlet.
- A pre-treatment stage handles extremely high concentrations while subsequent high-efficiency stages remove the remainder of the toxic vapors.
- During catastrophic releases, the EVS-150 achieves more than 99.999% chlorine vapor removal efficiency.

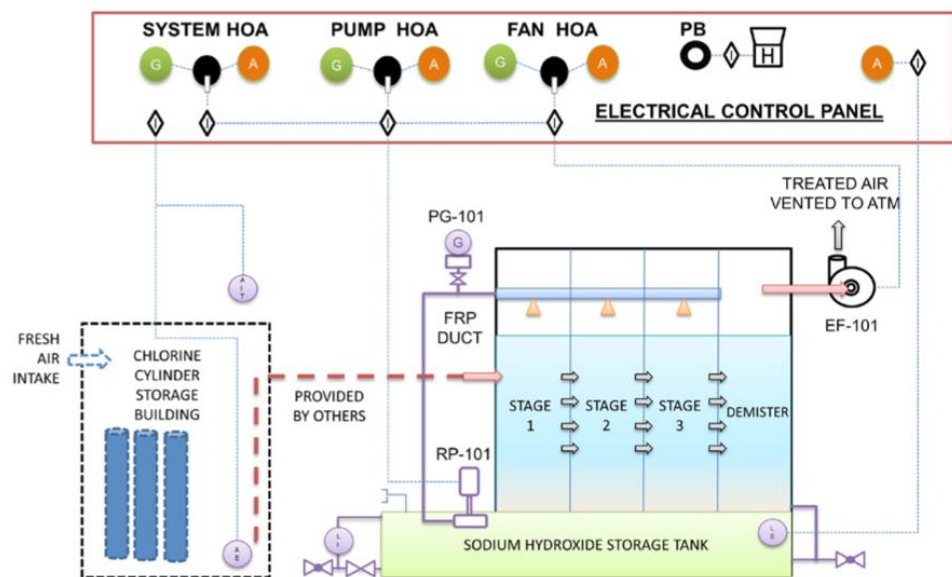

EVS-150 - Process & Instrumentation Diagram

Major System Components

- FRP Scrubber Vessel
- Integral FRP Caustic Storage Tank
- FRP Exhaust Fan
- Caustic Recirculation Pump
- FRP Control Panel
- FRP Exhaust Stack

How it Works

The emergency chlorine vapor scrubbing system is a three-stage chemical absorption system consisting of a horizontal crossflow spray system followed by two horizontal crossflow packed bed sections. An induced draft fan pulls vapors through the scrubber, where intimate contact with a recirculating caustic solution results in the complete absorption and removal of chlorine or sulfur dioxide vapors. A high efficiency mist eliminator is located in the gas stream, prior to exhaust, to remove any residual caustic solution.

A chlorine detector or manual remote start switch activates the system in two steps. The caustic pump is activated first to permit proper wetting of packing in the scrubber stages before starting the exhaust fan, with a 0 to 5 second adjustable time delay. The time delay is typically set for 3 to 5 seconds. This feature allows the scrubber to be ready prior to passing any chlorine laden gases through it.

The exhaust fan is placed downstream of the scrubber. This feature allows the complete system to be under negative pressure until the gases are completely scrubbed. The absorber is placed on top of a caustic storage tank, which is an integral part of the system.

System Features	System Benefits
Factory-assembled, Packaged System	<ul style="list-style-type: none"> System is assembled, piped, wired and tested at factory Enables better quality control at the factory Easier transportation, handling and installation
Minimum Installation, Cost and Time	<ul style="list-style-type: none"> Installation time of less than 8 hours Installation requires only provision of concrete pad, inlet ductwork, utility connections and fill of caustic soda
Superior Design and High Performance	<ul style="list-style-type: none"> Excess liquid to absorb heat of absorption for maximum chlorine release Low pressure recirculation of scrubber liquid enhances safety Three-stage chemical process ensures efficiency greater than 99.999% Random packing provides large surface area for gas-liquid contact
Low Cost of Operation & Easy Maintenance	<ul style="list-style-type: none"> Low profile with top and side access for easy maintenance Vertical seal-less pump Low horsepower for pump and fan motors
Automatic and Manual Operation	<ul style="list-style-type: none"> System can run in manual mode for maintenance purposes and in fully automatic mode for standby emergency operation
Optional Features for Maximum Safety	<ul style="list-style-type: none"> Standby recirculation pump Standby induced exhaust fan Sump insulation / sump heater

EVS-150 Design Information

Model	Design Capacity lbs (kg)	Airflow Rate CFM (m ³ /h)	Caustic Volume Gallons (Liters)	Overall Dimension L x W x H ft (m)	Shipping Weight lbs (kg)	Operating Weight lbs (kg)	Pump Motor HP (kw)	Fan Motor HP (kw)
EVS-150-2	300 (135)	250 (425)	275 (1040)	7.0 x 3.0 x 4.8 (2.1 x 0.9 x 1.5)	1,000 (450)	4,000 (1800)	3.0 (2.2)	1.0 (0.75)
EVS-150-4	600 (270)	250 (425)	550 (2082)	7.0 x 3.0 x 6.5 (2.1 x 0.9 x 2.0)	1,500 (700)	7,500 (3400)	3.0 (2.2)	1.0 (0.75)
EVS-150-6	900 (400)	250 (425)	660 (2500)	7.0 x 3.0 x 7.5 (2.1 x 0.9 x 2.3)	2,000 (900)	9200 (4200)	3.0 (2.2)	1.0 (0.75)

cleanwater1

13135 Danielson Street, Suite 204 | Poway, CA 92064
Tel: 858.486.1620 | Email: info@cleanwater1.com

cleanwater1.com

© 2025 Cleanwater1, Inc. Subject to change without prior notice.

The information provided in this literature contains merely general descriptions or characteristics of performance which in actual case of use do not always apply as described or which may change as a result of further development of the products. An obligation to provide the respective characteristics shall only exist if expressly agreed in the terms of a written contract.